

Numatic

BUILT FOR
MORE



Numatic BUILT FOR MORE

We do more for our customers.
Always have.
Always will.





BUILT FOR MORE PRODUCTIVITY

Are you NX?

Join over 100,000 people working smarter with NX300 Pro Cordless.

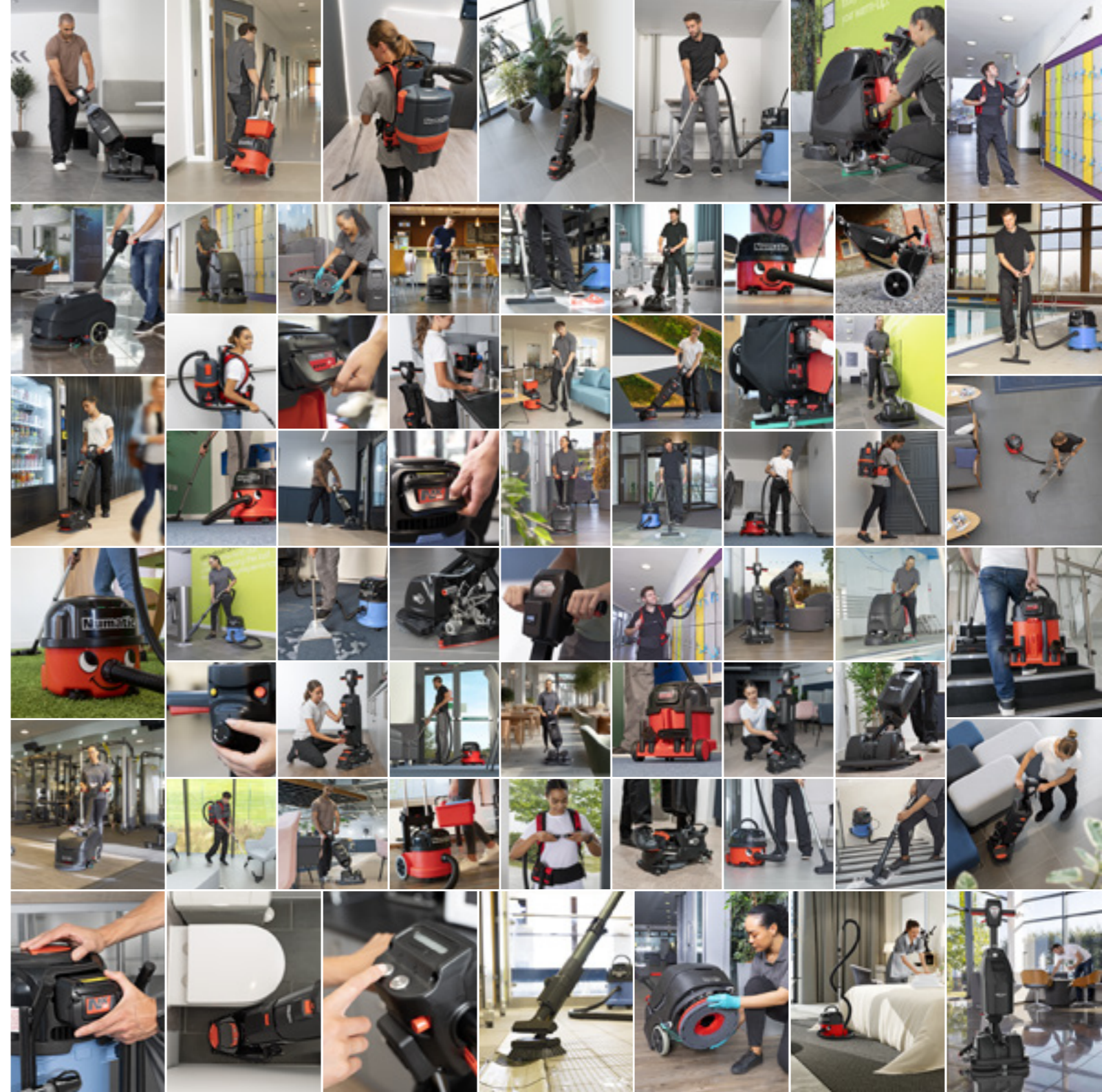







The Fastest-Growing Pro Cordless Battery Network

3 NEW PRODUCTS for 2026



Why Pro Cordless?

- 
More Time to Clean
- 
Lower Maintenance
- 
No Cable Trips
- 
Lower Noise
- 
Lower Energy Cost
- 
All Hours Cleaning



Cordless isn't a feature upgrade. It's a productivity upgrade.

- ✓ 20% Faster Cleaning*
- ✓ Reduced Trip Hazards
- ✓ Increased Operator Mobility in Congested Areas
- ✓ One-Fits-All Reduces Equipment Cost



NX300 Battery What's New for 2026

Built for tough environments, the new NX300 battery pack delivers stronger, smarter performance with:

- ✓ IPX6 Ingress Protection: IPX6 Market-leading enhanced water ingress protection for everyday durability.
- ✓ Improved Display: Clear, easy-read charge indicator.
- ✓ 3-Year Warranty: Long-term reliability for your Pro Cordless Network.



*Time and motion study evidencing faster cleaning from reduced plugging/unplugging, cable management and increased operator mobility.

*Please note: Images of the battery and charger may vary from product.

RSB Pro 5

Total Performance. No Compromise.

The most complete backpack vacuum on the market, providing best-in-class performance with every use.

- ✓ Lightweight & Ultra-Slimline Design
- ✓ Maximum Coverage with 80mins Runtime
- ✓ Supportive, Comfortable Harness
- ✓ Ultimate Hygiene Standards with HEPA13 Filter
- ✓ Made Using 29% ReFlo Recycled Material
- ✓ One-Fits-All NX300 Pro Cordless Network
- ✓ Extend Versatility with Additional Height & Productivity Kits

NEW PRODUCT

Detachable, Washable Harness

Numatic
3
YEAR WARRANTY

1
HOUR
FAST CHARGE

ONE-FITS-ALL BATTERY

ReFlo
TECHNOLOGY

Optional HEPA13 Filter

Battery Enclosure

Ultra-Slimline Design

BUILT FOR YOU

x4 Faster Cleaning

Lightweight with powerful cordless performance, the RSB Pro 5 significantly increases cleaning efficiency.

Based on ISSA Cleaning times comparison vs corded cylinder.

Specifications

5L Capacity	350W Motor	6KG Weight
Power Lithium Battery 36V		Runtime Hi 50 / Lo 80mins
Recharge Time 1hr 80% / 2hrs 100%		Optional HEPA13 Filtration
Dimensions (HxWxD) 521x305x204mm		

*Specifications are provisional only.



Quick Release Hose



Integrated Impact-Resistant Battery Enclosure



NuClean Pulse

Big Performance. Max Efficiency.

- ✓ High-Performance Microimpulse Technology
- ✓ Edge-to-Edge Cleaning Coverage
- ✓ 3,000 Oscillations/pm for Deep, Effective Cleaning
- ✓ Advanced HEPA Filtration
- ✓ Lightweight Handling, Easy-to-Use Design
- ✓ One-Fits-All NX300 Pro Cordless Network



BUILT FOR YOU

3000 Oscillations

High-performance 3,000 oscillations per minute, true deep-cleaning made effortless with lightweight handling and simple operation.

Specifications

NCS1240NX

12L Tank Capacity	14L Recovery Tank Capacity	220W Vac Motor	250W Brush Motor
Runtime 1 Battery up to 1hr / 2 Battery up to 2hrs			
Recharge Time 1hr 80% / 2hrs 100%		Water Flow Rate 0-0.5l/min	
Weight on Deck 22Kg		Cleaning Width 390x230mm	

NCS3050NX

30L Tank Capacity	30L Recovery Tank Capacity	280W Vac Motor	400W Brush Motor
Runtime 2 Battery up to 1hr 20mins			
Recharge Time 1hr 80% / 2hrs 100%		Traction Motor 100W	
Weight on Deck 28.5Kg		Cleaning Width 460x300mm	



Part of the NX300 Pro Cordless Network





BUILT FOR **MORE**
PERFORMANCE

No.1 in Cleaning Performance.

Unrivalled cleaning results with faster,
more productive, one-pass cleaning
performance every time.



NuClean Compact Range



Choose...

- ✓ Performance
- ✓ Reliability
- ✓ Efficiency
- ✓ Value
- ✓ Safety
- ✓ 3-Year Warranty
- ✓ Sustainability
- ✓ NX300 Pro Cordless Network



220NX 100
Unmatched Value,
Cordless Innovation

220NX
Small Size,
BIG Payback

440NX
Unstoppable
Performance

440NX Flex
FlexCore
Lighter Handling

440NX Drive
Driven
Performance

BUILT FOR YOU



Independent testing shows the 440NX
x3 times more effective in cleaning
than it's nearest competitor.



440NX

NUCLEAN
COMPACT

Meet the Range...



440NX



The All-Round Performer

- ✓ Compact, Cordless Cleaning
- ✓ One-Pass Performance
- ✓ One-Fits-All NX300 Pro Cordless Network

440NX Flex



For Compact, High-Traffic Spaces

- ✓ 25% Lighter Handling*
- ✓ FlexCore Technology
- ✓ Perfect for Compact Congested Areas

440NX Drive



From Tight Corners to Expansive Spaces

- ✓ Powered-Handling, Effortless Control
- ✓ 48% Increased Cleaning Coverage
- ✓ Faster Transit Between Cleaning Sites



Smarter Cleaning Starts Here
Calculate how much you can save and how far your cleaning investment can go.

clean360.numatic.com



*Lighter Handling vs 440NX

220NX

Ultra-Compact, Agile & Manoeuvrable.

- ✓ Designed for Demanding Commercial Use
- ✓ Replace Mopping in Hard-to-Reach, Congested Areas
- ✓ Save Over 5000L of Water & 80% Chemical Reduction
- ✓ Made Using 30% Recycled Plastic*1
- ✓ One-Fits-All NX300 Pro Cordless Network

CLEAN 360

Smarter Cleaning Starts Here
Calculate how much you can save and how far your cleaning investment can go.

clean360.numatic.com



Specifications

1L Tank Capacity	1.5L Recovery Capacity	100W Vac Motor
Runtime Up to 120mins		Recharge Time 1hr 80% / 2hrs 100%
Cleaning Width 220mm		Brush Speed 140RPM

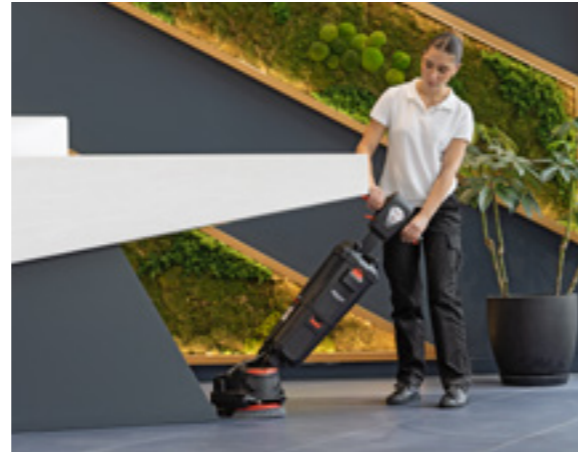

Agile & Lightweight



Ultra-Compact Cleaning Width



Introducing the 220NX 100
Our best value compact scrubber dryer,
part of the **new NX100 Pro Cordless Network**.

See page 30 for full product details.



NUCLEAN COMPACT 220

SMALL SIZE BIG PAYBACK

Switching to a 220NX for just **30 minutes** a day instead of wet mopping makes big savings, **returning** the total machine cost in under 1 year.*2

*1 30% represents the minimum use of recycled plastic content in 220NX, including accessories, excluding NX300 charger.

*2 Payback based on 300m² area clean, 7 days p/w, labour £11.44p/h VS wet mopping.





BUILT FOR **MORE**
DURABILITY

**Always On.
Always Ready.**

NuClean Professional raises the standard for durability, reducing ownership costs and backed by a 5-Year Warranty.



*5-Year Warranty subject to regional availability and terms.



NuClean Professional Range



Durability That Pays Off.

The NuClean Professional range is engineered from the ground up to deliver market-leading performance, unmatched reliability, effortless operation, and lower cost.

- ✔ Market-Leading 5-Year Warranty*¹
- ✔ Unrivalled Durability - Eliminate Routine Servicing
- ✔ Powered by NX1K Lithium Phosphate Battery Technology
- ✔ Long-Life & High-Efficiency Brushless Digital Motors
- ✔ Economical Dosing System - Reduce Chemical Use
- ✔ HEPA Filtration - Increase Hygiene Standards

BUILT FOR YOU



Zero Servicing

Engineered to remove the need for routine servicing, with long-life NX1K Lithium Phosphate batteries and digital motors.*²

40%
↓
Total Cost of Ownership

Cleaning Performance

Our most powerful clean yet, combining optimised weight distribution and high-torque digital motors for exceptional one-pass results.



One Platform, Total Choice

Flexible options: capacity, batteries, brushes, drive systems and telemetry.

Easy to Use & Maintain

Featuring colour-coded touchpoints, tool-free user maintenance, and instant training via Nu-Assist.



NuClean Pro can reduce Total Cost of Ownership by 40% over a five year period, by eliminating service costs and replacement of traditional lead batteries.

*¹ BLDC vacuum and brush motors
*² 5-Year Warranty subject to regional availability and terms.

NU-Assist **NU-Track**

Supported by Numatic Digital Services, offering user training, support, and telemetry insights.



One Platform. Total Choice.

Tank Capacity	Deck Width				Batteries			Optional Extras			
	450mm	550mm	720mm	850mm	1	2	3	HEPA	Dosing	Traction	Nu-Track
40L	Single / Dual Brush	Single / Dual Brush	—	—			—				
60L	—	Single / Dual Brush	Dual Brush	Dual Brush	✔	✔		✔	✔	✔	✔
80L	—	—	Dual Brush / 2-in-1 Deck	Dual Brush			✔				

Introducing the 2-in-1 Scrub Sweep Deck Option - Bringing together the power of a sweeper and the efficiency of a scrubber dryer. Delivering two essential functions in one smart and seamless unit.



BUILT FOR **MORE**
EFFICIENCY

**Smaller Spaces.
Smarter Power.
Bigger Value.**

NX100 Pro Cordless Network,
unlocking productivity for all.



Smaller Spaces. Smarter Power. Bigger Value.



The New NX100 Cordless Network... Unlocking Pro Cordless Productivity for All.

- ✓ Faster Cleaning in Compact & Hard-to-Reach Spaces
- ✓ Reduced Trip Hazards
- ✓ Best Value Pro Cordless Network
- ✓ NX100 One-Fits-All Reduces Equipment Cost



Optimised Cell Form Configuration for Greater Power-to-Weight Ratio

Durable, Impact-Resistant Construction

IPX7 Ingress Protection

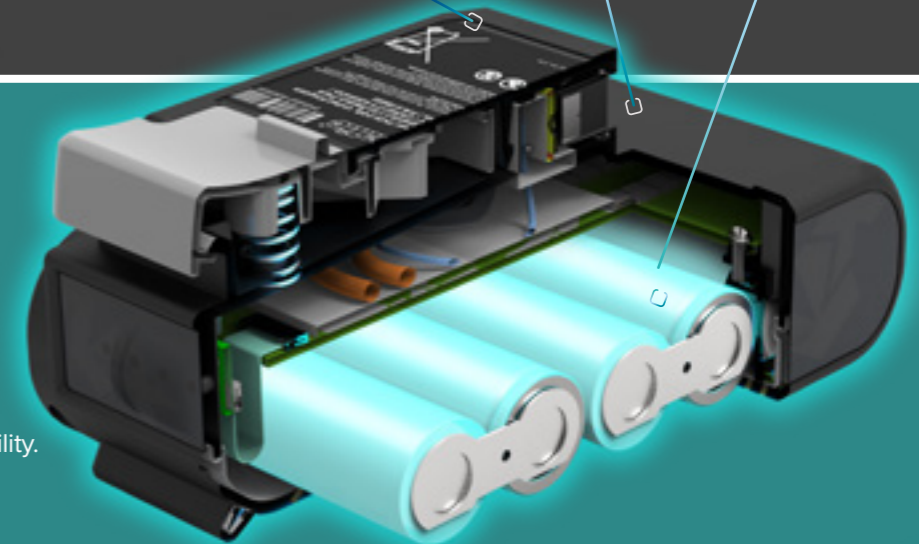

NX100 Battery New for 2026



- ✓ NX100 cell architecture provides high energy density with lightweight and compact design.
- ✓ IPX7 Ingress Protection: IPX7 Market-leading enhanced water ingress protection for everyday durability.
- ✓ Extend runtime further with optional high-capacity 8Ah battery.

Why Pro Cordless?

- More Time to Clean
- Lower Maintenance
- No Cable Trips
- Lower Noise
- Lower Energy Cost
- All Hours Cleaning

RSB Pro 3

Faster. Lighter. Smarter.

The RSB Pro 3 is the ultimate lightweight backpack vacuum, easy to wear and effortless to move in tight spaces. Designed for faster cleaning and maximum manoeuvrability.

- ✓ Ultra-Lightweight & Slimline Design
- ✓ Supportive, Comfortable Harness
- ✓ High-Performance Digital Motor
- ✓ Made Using 27% ReFlo Recycled Material*
- ✓ New One-Fits-All NX100 Pro Cordless Network
- ✓ Extend Versatility with Additional Height & Productivity Kits

NEW PRODUCT



Numatic
3
YEAR
WARRANTY

ONE-FITS-ALL BATTERY

ReFlo
TECHNOLOGY

x2 Quick Release Batteries

Optional HEPA13 Filter

Slim 204mm Depth

ULTRA-SLIM DESIGN



Ultra-Slimline Design Enhances Mobility & Comfort

Easy Battery Access

BUILT FOR YOU

Improved Biomechanics, Reduced Fatigue

The slimline design keeps weight close to the body, delivering a 45% reduction in centre-of-gravity adjustment.

Specifications

3L Capacity	350W Motor	4.8KG Weight
Power Lithium Battery 2 x 18V		Runtime Hi 22 / Lo 40mins
Recharge Time 50mins 80% / 75mins 100%		Optional HEPA13 Filtration
Dimensions (HxWxD) 431x305x204mm		

*Specifications are provisional only.



220NX 100

Unbeatable Value.
High-Performance.
Ultra-Compact Cleaning.

The 220NX 100 delivers the cleaning performance of much larger scrubber dryers in an ultra-compact package, reaching areas traditionally cleaned by mopping alone for better results and reduced labour costs.

A true high-value solution, unlocking professional cordless cleaning powered by the new NX100 Pro Cordless battery platform.

- ✓ Ultra-Compact, Agile & Manoeuvrable
- ✓ Perfect for Congested & Hard-to-Reach Areas
- ✓ Save Over 5000L of Water & 80% Chemical Reduction
- ✓ Made Using 30% ReFlo Recycled Plastic*
- ✓ New One-Fits-All NX100 Pro Cordless Network

NEW PRODUCT



Specifications

1L Tank Capacity	1.5L Tank Capacity	100W Vac Motor
Runtime Up to 30mins	Recharge Time 100mins 80% / 130mins 100%	
Cleaning Width 220mm	Brush Speed 140RPM	

*Specifications are provisional only.



Ultra-Compact Cleaning Width



Easy to Use Controls



Easy to Access Interchangeable Battery

PRODUCT PREVIEW

QUICK Q2

Next Generation Pro Cordless Vacuum.

New Features:

Anti-Hair Wrap Technology
Auto-Floor-Sense Detection
Integrated Tools

- ✓ Over 70 Minutes of Powerful Cordless Performance
- ✓ Designed & Tested for the Demands of Commercial Cleaning
- ✓ New One-Fits-All NX100 Pro Cordless Network



BUILT FOR **MORE**
VERSATILITY

**One System.
Infinite Flexibility.**

Limitless configuration, advanced features, XTRA-Matic sets the standard in every application.



XTRA-Matic

One System.
Infinite Flexibility.

Versatile, durable, and ready for any environment, XTRA-Matic is designed to support the full spectrum of professional cleaning tasks with ease.

- ✓ Built-in Antimicrobial Technology
- ✓ Optimised for Multiple Cleaning Tasks
- ✓ Designed for Quick & Effective Sanitisation
- ✓ Flexible in Use, Simplicity & Storage
- ✓ Premium Nordic Swan 3.0 Certified Mops
- ✓ Made Using 50% ReFlo Recycled Plastic

**NEW
PRODUCT**

Antimicrobial Touch-Points



**NEW
PRODUCT**

**XM1 + XM2
+ XM3**

XM1 + XM-SD

Mop Dosing System

Aluminium Doors

BUILT FOR YOU



Antimicrobial

99.9% Touch-points made with antimicrobial additives, supporting infection control.



Internal Storage & Drawer Options



Multiple Detachable Accessory Points



Built-in Antimicrobial Touch-Points



Nu-Design Coming Soon to Nu-Design

A step-by-step configurator: build your trolley, your way.



XTRA-Matic

Your Trolley, Your Choice...

Build the perfect configuration your way. Total flexibility for every cleaning task.

Start Here

Choose a Single Unit

XM1

Perfect for compact spaces, a small footprint with big storage or waste option potential.



Need Mopping?

Pick your Mopping Solution

XM1 + XM3

Choose from 5 different options for mopping solutions including traditional wet, flat, velcro, pocket, or hang-on systems.

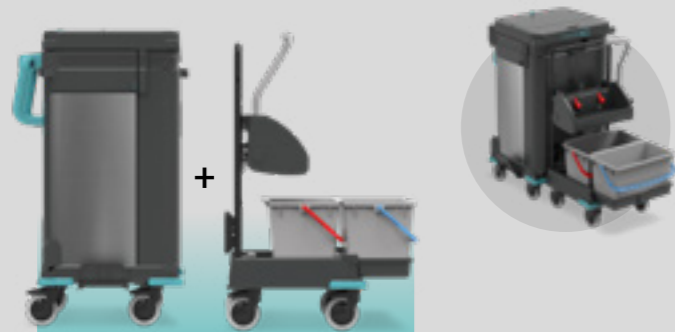

Prefer Dosing?

Add a Single Mop Dosing System

XM1 + XM-SD

Our new single mop dosing system delivers a controlled, measured and complete hands-free solution.

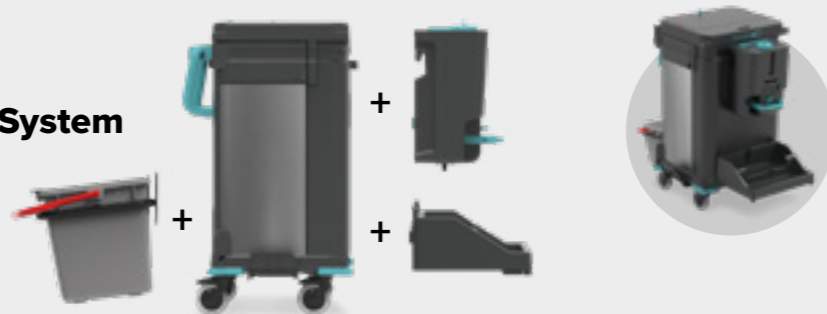

Need More Capacity?

Choose a Twin Unit

XM2

For bigger tasks that demand extra storage and expanded waste solutions.



Need Even More... & Mopping Too?

Select an XTRA Single Unit & Mopping Solution

XM1 + XM2 + XM3

Unlock maximum storage flexibility and extend your choice of multiple mopping systems.



or Prefer Dosing?

Choose our Twin Mop Dosing System

XM2 + XM-TD

for XTRA convenience and efficiency.



...and that's just the start



Nu-Design

XTRA-Matic Coming Soon to Nu-Design

A step-by-step configurator: build your trolley, your way.

DIGITAL SERVICES

Increase cleaning productivity with training, insights, and support at your fingertips.



Scan Me for Digital Services

NUMATIC **NU-Assist**

Training & Support

Access simple, versatile, and user-friendly online training.

NUMATIC **NU-Design**

Bespoke Trolley Configurator

A step-by-step configurator: build your trolley, your way.

NUMATIC **NU-Track**

Intelligent Fleet Management

See how, when, and where your cleaning fleet is operating.



Smarter Cleaning Starts Here

Calculate how much you can save and how far your cleaning investment can go.



Numatic

Head Office

Numatic International Limited

Chard, Somerset TA20 2GB UNITED KINGDOM

Tel: +44 (0) 1460 68600 numatic.com

For details on product claims, content, or messaging,
contact media@numatic.co.uk



**Sustainability
Report 2026**



**Full Range
Catalogue**



©Numatic International Limited 2026. All rights reserved.
Specification subject to change without prior notice. numatic.com
922515 03/26